

## PCI-RMS BRIDGE

### FEATURES

- High Speed Data Connection between Concept/32 RMS and PCI-RMS Nodes
- Bridges to either RMS I Bus or RMS II Bus
- Controlled by Configurable Memory Regions
- Provides RMS Bus (I or II) Arbitration and Termination

### BENEFITS

- Uses Existing RMS Bus Cables
- No Additional Software Required
- Connects Legacy Encore Computer Systems to Modern "Open" Computer Systems
- Available for Linux®, Windows XP® and NT®, HP® Tru64, OpenVMS, and Solaris®

The PCI-RMS Bridge provides a path between COMPRO's legacy Reflective Memory System (RMS) and the COMPRO's PCI-RMS Ring. The Bridge allows either RMS I or RMS II transfers to propagate to PCI-RMS nodes and PCI-RMS node transfers to flow onto the RMS I or RMS II Bus.

The Bridge provides a method for connecting nodes to an existing RMS Bus using "state-of-the-art" computing systems. This capability offers a seamless, non-intrusive mechanism to augment legacy systems with powerful new features using today's computing solutions.

By adding PCI-RMS nodes, the architecture can easily expand into a tightly-coupled "super-system", cooperatively working on the most challenging applications.

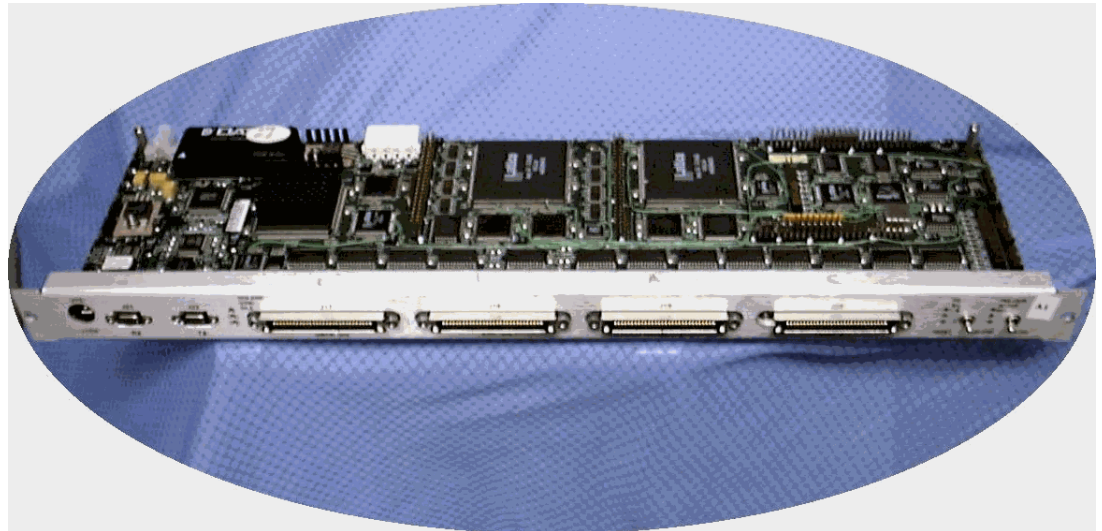

PCI-RMS Bridge

### Physical Description

The Bridge has a similar form factor to a Reflective Memory Controller (RMC). During installation, an RMC is removed from the RMC chassis and the Bridge is installed in its place.

Compatible RMS Bus cable connectors are provided for connection to the RMS Bus. Two copper PCI-RMS cable connectors are provide for connection PCI-RMS Ring nodes.

### Requirements

The Bridge requires one node ID on the RMS Bus (I or II) and one node ID on the PCI-RMS Ring:

- PCI-RMS Ring transfers below 16 MB/sec can be selected to pass to an RMS I Bus.
- PCI-RMS Ring transfers below 256 MB/sec can be selected to pass to an RMS II Bus.



**PCI-RMS BRIDGE (Cont'd)**

The following block diagram illustrates how a PCI-RMS Ring connects to a Concept RMS Bus using the RMS Bus to PCI-RMS Bridge.

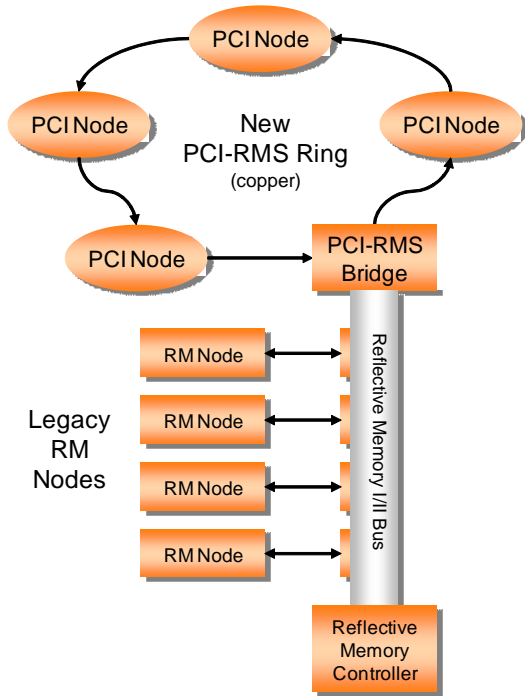

**Specifications**

Specification	Description	
<b>Physical Characteristics</b>		
Model No.	160-113458-xxx	
Depth	4.41 inches (12.217 centimeters)	
Height	15.95 inches (40.513 centimeters)	
Weight	1.6 lbs (0.73 kilograms)	
<b>Electrical Characteristics</b>		
Voltage	<ul style="list-style-type: none"> <li>5.0 VDC +/- 5%</li> <li>12.0 VDC +/- 5%</li> </ul>	
Current	<ul style="list-style-type: none"> <li>7 amps, 5 volts</li> <li>1 amp, 12 volts</li> </ul>	
<b>Ring Healing External Power Requirements</b>		
Voltage	12 VDC +/- 5%	
Current	1 amp	
<b>Environmental Characteristics</b>		
Operating	Temperature:	32° F to 104° F (0° C to 40° C)
	Relative Humidity	5% to 95%
Storage	Temperature:	32° F to 104° F (0° C to 40° C)
	Relative Humidity	20% to 80%



COMPRO Computer Services, Inc.  
 105 East Drive  
 Melbourne, Florida U.S.A.  
 Tel: (800) 936-2673  
 www.compro.net



**INTERNATIONAL BUSINESS PARTNERS**



**Brazil**  
 Flight Simulator System, Ltda.  
 Tel: +55 (12) 3322-0470  
 www.fssbrasil.com.br

**Italy**  
 Encore Real Time Computing S.r.l.  
 Tel.: +39 0362 300433  
 www.encore.it

**United Kingdom**  
 COMPRO Services Ltd.  
 Tel.: +44 (0) 1252 852228  
 www.compro-uk.com

**Germany**  
 Encore Real Time Computing GmbH  
 Tel.: +49 21 31 92 43 32

**Spain**  
 Encore Real Time España S.A.  
 Tel.: +34-981-288404

**Japan**  
 Japan Encore Computer, Inc.  
 Tel.: +81-3-5791-4940